

Systemec[®] Prep/Semi-Prep Scale Vacuum Degassing Chambers

The Systemec Prep/Semi-Prep Scale degassing chambers are built for the rigors of modern preparative and semi-prep scale HPLC. Its unique design assures reliable continuous operation and the highest level of continuous performance available. The chambers are available in single or dual channel configurations, allowing two solvent lines to be degassed simultaneously by one unit.

- ▶ Ultra-high degassing efficiency
- ▶ Low volume
- ▶ Easy priming
- ▶ Dual lumen design for low-flow resistance

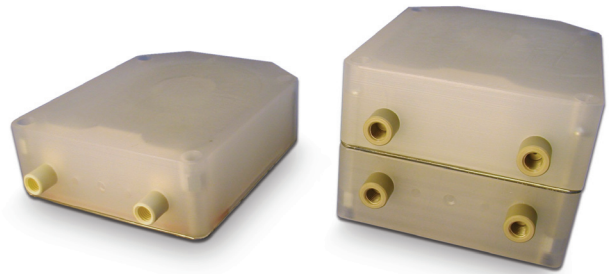

Systemec AF Degassing Technology

The prep / semi-prep scale degassing chambers are designed to be easy to prime, and are configured with a Systemec AF degassing membrane to provide maximum degassing capacity with the absolute minimum internal volume (<3% of PTFE designs with comparable degassing capacity).

The standard prep scale design has its internal degassing membrane configured as a dual lumen tubing coil assembly, optimal for low-pressure mixing LC applications. Chambers are available as single or dual-channel assemblies.

General Specifications

Degassing Channel Tubing:

- ▶ Systec AF™, 0.075 in. ID

Degassing Channel Pressure Rating:

- ▶ 70 PSIG (testing pressure)

Wetted Materials:

- ▶ Systec AF, PPS, Stainless Steel and Glass-filled PTFE

Vacuum Housing Materials:

- ▶ Polypropylene and Stainless Steel

Hardware:

- ▶ Stainless Steel

Overall Dimensions

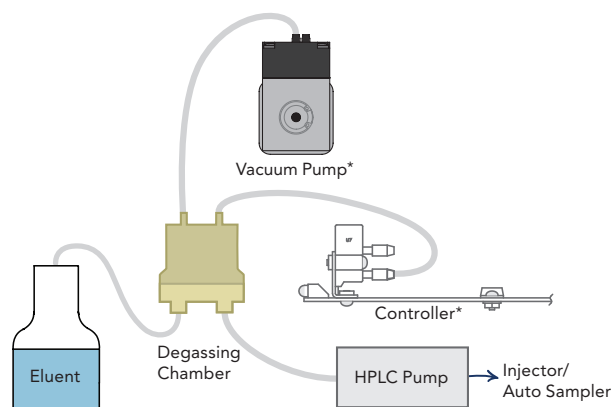
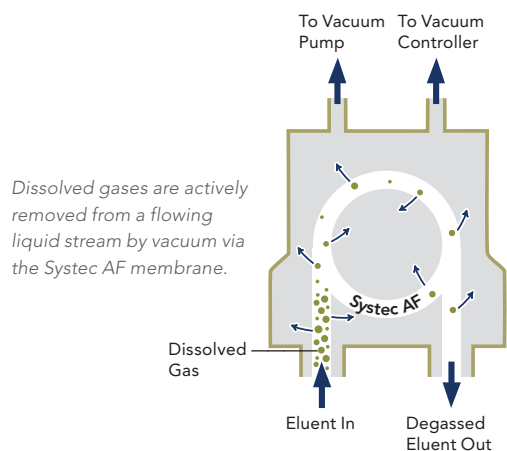
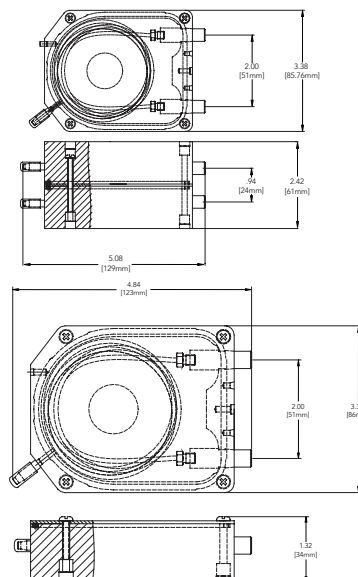

*See Systec® ZHCR® Vacuum Pump and Controller Product Data Sheet for more information.

Standard Dual Lumen Prep / Semi-Prep Degassing Configurations^{A, B}

Systec Part Number	1 Channel	2 Channel	Application	Channel Volume (mL)	Max HPLC Gradient Flow Capability ^C (mL/min)	Pressure Drop ^D (kPa/mL/min)
9000-1172	N/A	N/A	Prep	6.3	15	0.03
N/A	9000-1114	N/A	Prep	8.4	20	0.04
N/A	9000-1118	N/A	Prep	13.8	40	0.06

A. Custom configurations are available. Consult us for your own OEM solution to your specific application.

B. The standard prep scale chambers are not recommended for GPC applications or for use with HFIP (hexafluoroisopropanol).

C. The flow rates given are for a gradient mixture of 60/40 MeOH/H₂O, with a typical low pressure gradient mixing valve. Higher flow rates are possible with high pressure mixing.

D. Estimated tubing pressure per unit change in flow assuming laminar flow with a viscosity of 1.0 cP.

Systec® and ZHCR® are registered trademarks of IDEX Health and Science LLC.
Systec AF™ is a trademark of IDEX Health and Science LLC.
U.S. Patents 5,340,384; 6,248,157 and 6,494,938.
©2009 IDEX Health & Science LLC

SY7:500-03/2009

